

# Quality check

3DTransVidia verifies the quality of a 3D model definition according to the international automotive standards (VDA 4955, JAMA, and AIAG D-15). The quality criteria can be set by the user to meet internal company standards or reflect the model quality required in a manufacturing or simulation process.

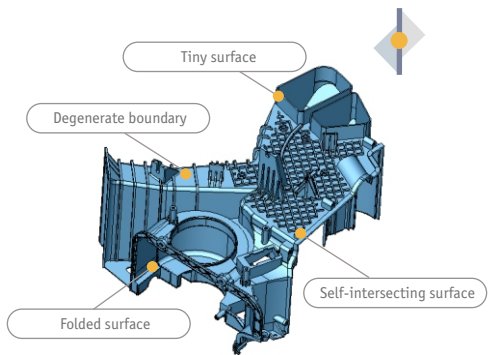

# Product Manufacturing Information

The Product Manufacturing Information (PMI) stored with a 3D model is now easily accessible from CATIA V5, UGX and Pro/E native files. PMI text and dimensions provide essential manufacturing information about tolerances, surface quality, tolerance for parallel walls or axis, etc. PMI information is displayed on the 3D model and accessible from the project tree. You can activate/hide PMI layers, change the font type, alter the letter size, edit dimensions, and print the PMI information for documentation purposes.

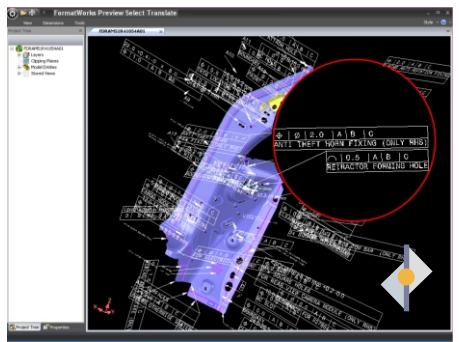

Capvidia NV Headquarters  
 Technologielaan 3  
 B-3001 Leuven, BELGIUM  
 Phone: +32 (16) 40 27 47  
 E-mail: info@capvidia.be  
 www.capvidia.com

Capvidia NA LLC  
 New Ulm, MN  
 Mobile: 507 276 2379  
 Phone: 507 794 5447  
 Fax: 507 794 5446  
 E-mail: lyle@capvidia.com

Irvine, CA  
 Mobile: 949 910 2916  
 E-mail: tk@capvidia.com

Supported Formats	Import	Export
CATIAV5 up to R21	+	+
CATIAV4 up to 4.2.4	+	+
ProE Wildfire 5.0	+	-
Unigraphics NX7.0	+	-
CAADS	+	-
IGES 6.0	+	+
STEP A203/A214	+	+
ACIS V.20	+	+
VDA-FS	+	+
and more...		

# 3DTRANSVIDIA2011

CAD DATA TRANSLATION, REPAIR AND HEALING

- CATIA V5
- CATIA V4
- PRO/E
- UGS NX
- SOLIDWORKS
- INVENTOR
- MASTERCAM
- SURFCAM
- DELCAM
- ACIS
- STEP
- IGES

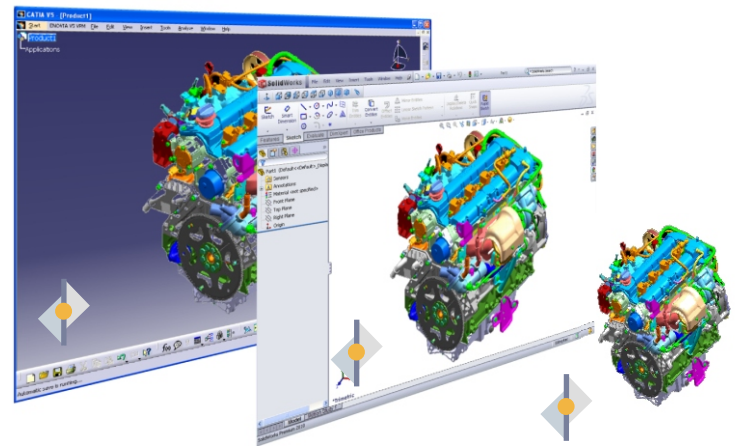

3DTransVidia is designed to repair 3D models created in different CAD systems. The repair process is automatic and can be applied to most complex 3D models and assemblies. The repair is always performed within the model tolerance maintaining the original model integrity and preventing model deformations. 3DTransVidia supports both native and neutral data formats.

CAD models often lack quality and precision required by the complex engineering processes (CAD -> CAE -> CAM). The geometrical and topological flaws are main obstacles in data translation. Complex CAD operations as model re-scaling, offsetting or Boolean operations are impossible to perform on invalid models. Repairs in native CAD system are in general difficult and time consuming as CAD system are not designed for this purpose.

3DTransVidia offers ultimate solutions to repair existing 3D CAD models to desired quality. Geometry check tools verify model compliance against the automotive industry standards as VDA 4955-2, JAMA and AIAG D-15 or user defined quality criteria.

### The repair process consists of the following steps:

- Data import
- Model tolerance control
- Automatic repair & healing
- Error classification
- Manual repair
- Quality check
- Data export

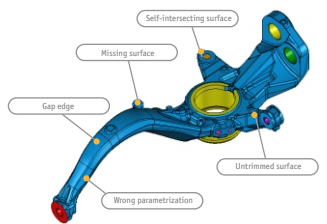

## Data Import

3DTransVidia solves frustrating data incompatibility problems occurring during the import of 3D models. It seamlessly imports native data formats (CATIA V4, CATIA V5, CADD5, P/E, UGS, etc.) and neutral data formats (IGES, VDA-FS, STEP, etc.) and performs necessary model repairs to form a valid solid.

## Model Tolerance

3DTransVidia automatically finds the right model tolerance value by verifying the size of all model entities. The user controls the model tolerance by choosing between the following options:

- File tolerance (value stored in the file)
- Estimated tolerance (recommended default value)
- User tolerance

## Automatic Repair

The automatic repair resolves over 60 typical geometry and topology conflicts. The repair is performed within a specified model tolerance without changing or deforming the original model. Even an inexperienced CAD user will complete the repair within very short time.

## Geometry Conflicts

- Invalid curve parameterization
- Gaps in composite curve Degenerative segments in polyline
- NURBS improving simplification of curve
- Incorrect knots vector in the NURBS curve

## Topology Conflicts

- Invalid edge vertices Invalid loop orientation in Parametric Space
- Missing loop definition in Model Space
- Missing loop definition in PS
- Invalid edge orientation Lack of loop synchronization
- Not closed loop
- Self-crossing loop in
- Missing outer loop in face definition
- Wrong index of outer loop Invalid loop orientation
- Inconsistent face normal

## Open contour diagnostics

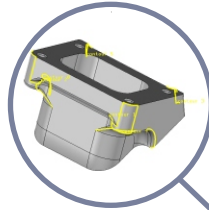

## Surface creation

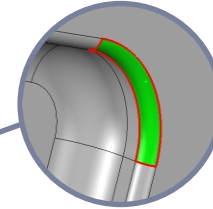

## Gap diagnostics

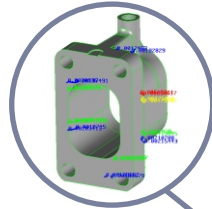

## Error Classification

3DTransVidia automatically classifies types of errors remaining in the model after automatic repair and suggests a most suitable manual repair workflow. Problematic places are visible in the project tree and remain there until they are fixed. The repair parts are automatically merged with the rest of the model. The errors are classified into the following categories:

- Gaps
- Overlaps
- T-connections
- Ledges
- Mesh open

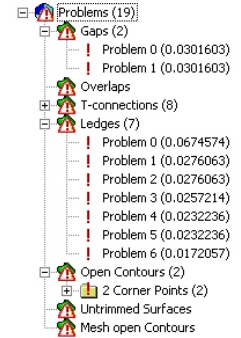

## Surface recreation

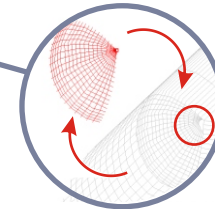

## Manual Repair

Manual repair has never been simpler. 3DTransVidia provides a workflow and special tools to easy and fast repair all remaining problems. Faulty places together with their neighbours are automatically isolated from the rest of the model. The user manipulates only on small part of the model instead of the whole model or complex assembly.

## Surface splitting

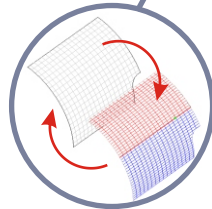

## Surface trimming

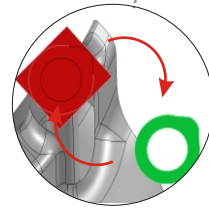

## Surface merging

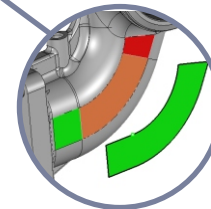

**3DTRANSVIDIA2011**  
CAD DATA TRANSLATION, REPAIR AND HEALING